

## SKS36-HFA0-K02

SKS/SKM36

MOTOR FEEDBACK SYSTEMS ROTARY HIPERFACE®

**SICK**  
Sensor Intelligence.

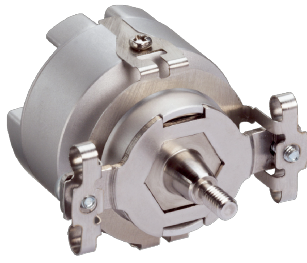

Illustration may differ



### Ordering information

Type	Part no.
SKS36-HFA0-K02	1034095

Other models and accessories → [www.sick.com/SKS\\_SKM36](http://www.sick.com/SKS_SKM36)

### Detailed technical data

#### Performance

<b>Sine/cosine periods per revolution</b>	128
<b>Number of the absolute ascertainable revolutions</b>	1
<b>Total number of steps</b>	4,096
<b>Measuring step</b>	2.5 " For interpolation of the sine/cosine signals with, e. g., 12 bits
<b>Integral non-linearity</b>	± 80 ", Error limits for evaluating sine/cosine period
<b>Differential non-linearity</b>	± 40 ", Non-linearity within a sine/cosine period
<b>Operating speed</b>	≤ 12,000 min <sup>-1</sup> , up to which the absolute position can be reliably produced
<b>Available memory area</b>	1,792 Byte
<b>System accuracy</b>	± 120 "

#### Interfaces

<b>Type of code for the absolute value</b>	Binary
<b>Code sequence</b>	Increasing, when turning the shaft For clockwise rotation, looking in direction "A" (see dimensional drawing), For clockwise shaft rotation, looking in direction "A" (see dimensional drawing)
<b>Communication interface</b>	HIPERFACE®

#### Electrical data

<b>Connection type</b>	Male connector, 8-pin, radial
<b>Supply voltage</b>	7 V DC ... 12 V DC
<b>Recommended supply voltage</b>	8 V DC
<b>Power consumption</b>	60 mA <sup>1)</sup>
<b>Output frequency for sine/cosine signals</b>	≤ 65 kHz
<b>MTTF: mean time to dangerous failure</b>	210 years (EN ISO 13849) <sup>2)</sup>

<sup>1)</sup> Without load.

<sup>2)</sup> This product is a standard product and does not constitute a safety component as defined in the Machinery Directive. Calculation based on nominal load of components, average ambient temperature 60 °C, frequency of use 8760 h/a. All electronic failures are considered hazardous. For more information, see document no. 8015532.

#### Mechanical data

<b>Shaft version</b>	Tapered shaft
<b>Flange type / stator coupling</b>	Spring mounting plate, stator coupling

<b>Dimensions</b>	See dimensional drawing
<b>Weight</b>	≤ 0.07 kg
<b>Moment of inertia of the rotor</b>	4.5 gcm <sup>2</sup>
<b>Operating speed</b>	12,000 min <sup>-1</sup> , 12,000 U/min
<b>Angular acceleration</b>	≤ 500,000 rad/s <sup>2</sup>
<b>Operating torque</b>	0.2 Ncm
<b>Start up torque</b>	+ 0.3 Ncm
<b>Permissible movement of the drive element, static</b>	± 0.1 mm radial - 0.4 mm axial + 0.2 mm axial
<b>Permissible movement of the drive element, dynamic</b>	± 0.05 mm radial ± 0.1 mm axial
<b>Life of ball bearings</b>	3.6 x 10 <sup>9</sup> revolutions

### Ambient data

<b>Operating temperature range</b>	-20 °C ... +110 °C
<b>Storage temperature range</b>	-40 °C ... +125 °C, without package
<b>Relative humidity/condensation</b>	90 %, Condensation not permitted
<b>Resistance to shocks</b>	100 g, 6 ms, 6 ms (according to EN 60068-2-27)
<b>Frequency range of resistance to vibrations</b>	50 g, 10 Hz ... 2,000 Hz (according to EN 60068-2-6)
<b>EMC</b>	According to EN 61000-6-2 and EN 61000-6-3 <sup>1)</sup>
<b>Enclosure rating</b>	IP50, with mating connector inserted and closed cover (according to IEC 60529)

<sup>1)</sup> The EMC according to the standards quoted is achieved when the motor feedback system is mounted in an electrically conductive housing, which is connected to the central earthing point of the motor controller via a cable screen. The GND-(0 V) connection of the supply voltage is also grounded here. If other shielding concepts are used, users must perform their own tests.

### Classifications

<b>ECl@ss 5.0</b>	27270590
<b>ECl@ss 5.1.4</b>	27270590
<b>ECl@ss 6.0</b>	27270590
<b>ECl@ss 6.2</b>	27270590
<b>ECl@ss 7.0</b>	27270590
<b>ECl@ss 8.0</b>	27270590
<b>ECl@ss 8.1</b>	27270590
<b>ECl@ss 9.0</b>	27270590
<b>ECl@ss 10.0</b>	27273805
<b>ECl@ss 11.0</b>	27273901
<b>ETIM 5.0</b>	EC001486
<b>ETIM 6.0</b>	EC001486
<b>ETIM 7.0</b>	EC001486
<b>ETIM 8.0</b>	EC001486
<b>UNSPSC 16.0901</b>	41112113

**Dimensional drawing** (Dimensions in mm (inch))

General tolerances according to DIN ISO 2768-mk

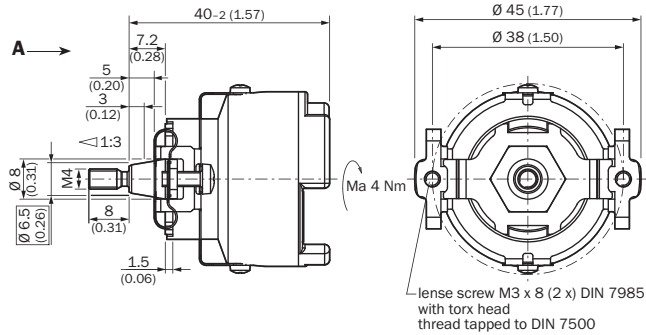

**Attachment specifications**

General tolerances according to DIN ISO 2768-mk

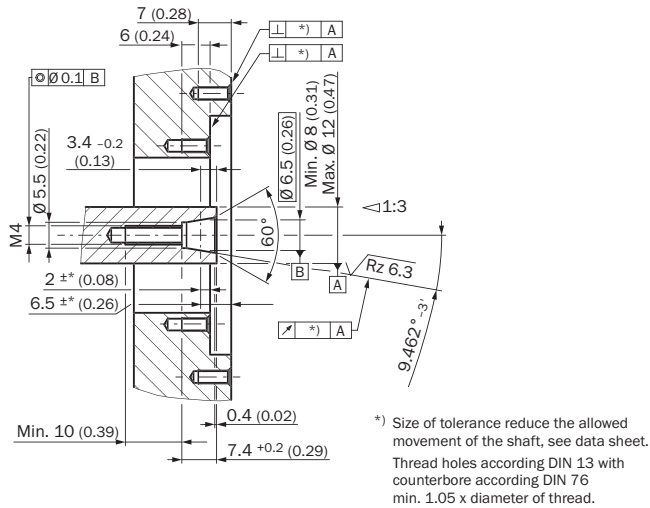

**PIN assignment**

PIN	Signal	Colour of Wires	Explanation
1	U <sub>s</sub>	red	Supply voltage 7 ... 12 V
2	+ SIN	white	Process data channel
3	REFSIN	brown	Process data channel
4	+ COS	pink	Process data channel
5	REFCOS	black	Process data channel
6	GND	blue	Ground connection
7	Data +	grey or yellow	RS-485-parameter channel
8	Data -	green or purple	RS-485-parameter channel

The housing is electrically connected to the motor housing, via the stator coupling.  
 The GND (0 V) connection of the supply voltage has no connection to the housing.



View of the plug-in face

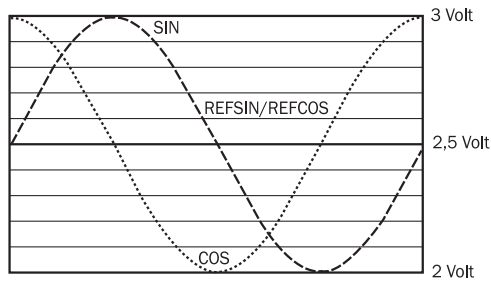

## Diagrams

Signal diagram for clockwise shaft rotation, looking in direction "A" (see dimensional drawing) 1 period = 360° : 128



## Recommended accessories

Other models and accessories → [www.sick.com/SKS\\_SKM36](http://www.sick.com/SKS_SKM36)

	Brief description	Type	Part no.
Programming and configuration tools			
	SVip® LAN programming tool for all motor feedback systems	PGT-11-S LAN	1057324
Other mounting accessories			
	BEF-MW-SKX36	BEF-MW-SKX36	2031079
Plug connectors and cables			
	Head A: female connector, JST, 8-pin, straight Head B: Flying leads Cable: HIPERFACE®, unshielded, 0.2 m	DOL-OJ08-G0M2XB6	2031086

## SICK AT A GLANCE

SICK is one of the leading manufacturers of intelligent sensors and sensor solutions for industrial applications. A unique range of products and services creates the perfect basis for controlling processes securely and efficiently, protecting individuals from accidents and preventing damage to the environment.

We have extensive experience in a wide range of industries and understand their processes and requirements. With intelligent sensors, we can deliver exactly what our customers need. In application centers in Europe, Asia and North America, system solutions are tested and optimized in accordance with customer specifications. All this makes us a reliable supplier and development partner.

Comprehensive services complete our offering: SICK LifeTime Services provide support throughout the machine life cycle and ensure safety and productivity.

For us, that is “Sensor Intelligence.”

## WORLDWIDE PRESENCE:

Contacts and other locations –[www.sick.com](http://www.sick.com)